



ETA-Danmark A/S
Göteborg Plads 1
DK-2150 Nordhavn
Tel. +45 72 24 59 00
Fax +45 72 24 59 04
Internet www.eta danmark.dk

Authorised and notified according
to Article 29 of the Regulation (EU)
No 305/2011 of the European
Parliament and of the Council of 9
March 2011

MEMBER OF EOTA



European Technical Assessment ETA-09/0015 of 2021/04/06

I General Part

Technical Assessment Body issuing the ETA and designated according to Article 29 of the Regulation (EU) No 305/2011: ETA-Danmark A/S

Trade name of the construction product:

Joist Hangers Type A , B and I (Kombi and Innen)

Product family to which the above construction product belongs:

Three-dimensional nailing plate (Joist hanger for wood to wood connections and wood to concrete or steel connections)

Manufacturer:

G. Verbindungssysteme GmbH & Co.
Rudolf-Diesel-Strasse 1
D-58730 Fröndenberg, Industriegebiet

Manufacturing plant:

Rudolf-Diesel-Strasse 1
D-58730 Fröndenberg, Industriegebiet

This European Technical Assessment contains:

23 pages including 4 annexes which form an integral part of the document

This European Technical Assessment is issued in accordance with Regulation (EU) No 305/2011, on the basis of:

EAD 130186-00-0603 for Three-dimensional nailing plates

This version replaces:

The previous ETA with the same number issued on 2021-01-11

Translations of this European Technical Assessment in other languages shall fully correspond to the original issued document and should be identified as such.

Communication of this European Technical Assessment, including transmission by electronic means, shall be in full (excepted the confidential Annex(es) referred to above). However, partial reproduction may be made, with the written consent of the issuing Technical Assessment Body. Any partial reproduction has to be identified as such.

II SPECIFIC PART OF THE EUROPEAN TECHNICAL ASSESSMENT

1 Technical description of product and intended use

Technical description of the product

G. joist hangers type A, B and I are one-piece non-welded, face-fixed joist hangers to be used in timber to timber connections. Gutzeit joist hangers type A are also used for connections between a timber joist and a concrete structure or a steel member.

The joist hangers are made from hot-dipped-coated steel Grade SD250GD + Z (min Z275) according to EN 10346 with a minimum R_e of 250 MPa, a minimum tensile strength R_m of 330 MPa and a minimum ultimate strain A_{80} of 22 % with tolerances according to EN 10143. Dimensions, hole positions, steel type and typical installations are shown in Annex A.

The joist hangers can also be produced from hardened stainless steel number 1.4301, 1.4401, 1.4541 and 1.4571 in strength class CP350 according to EN 10088-4 or a stainless steel with a strength class CP350 according to EN 10088-4. Tolerances are according to EN ISO 9445

2 Specification of the intended use in accordance with the applicable European Assessment Document (hereinafter EAD)

The joist hangers are intended for use in making end-grain to side-grain connections in load bearing timber structures, as a connection between a wood based joist and a solid timber or wood based header, where requirements for mechanical resistance and stability and safety in use in the sense of the Basic Works Requirements 1 and 4 of Regulation (EU) 305/2011 shall be fulfilled. The joist hangers type A are also intended for use in making an end-grain connection between a timber joist and a concrete structure or a steel member.

The joist hangers can be installed as connections between wood based members such as:

- Structural solid timber classified to C14-C40 according to EN 338 / EN 14081,
- Glulam classified to GL24-GL36 according to EN 1194 / EN 14080,
- LVL according to EN 14374,
- Parallam PSL,
- Intrallam LSL,

- Duo- and Triobalken,
- Layered wood plates,
- I-beams with backer blocks on both sides of the web in the header and web stiffeners in the joist,
- Plywood according to EN 636.

However, the calculation methods are only allowed for a characteristic wood density of up to 460 kg/m^3 . Even though the wood based material may have a larger density, this must not be used in the formulas for the load-carrying capacities of the fasteners.

Annex B states the formulas for the characteristic load-carrying capacities of the connections with joist hangers. The design of the connections shall be in accordance with Eurocode 5 or a similar national Timber Code.

It is assumed that the forces acting on the joist hanger connection are the following F_{up} , F_{down} and F_{lat} , as shown in the figure below. The forces F_{up} and F_{down} shall act in the middle of the joist hanger. The force F_{lat} is assumed to act $e_{J,90}$ above the centre of gravity of the nails in the joist. It is assumed that the forces are acting right at the end of the joist.

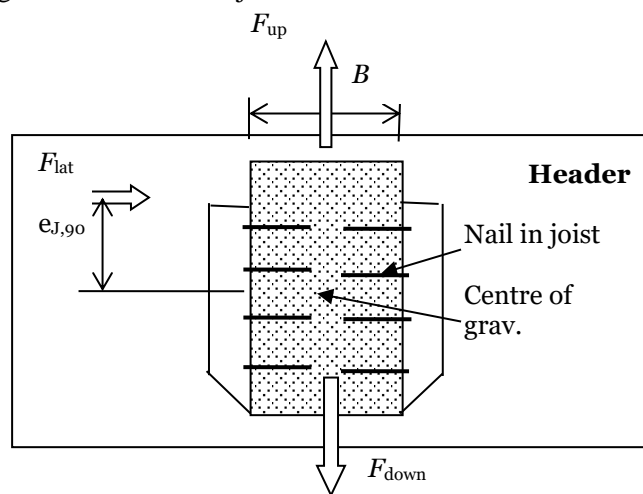

It is assumed that the header beam is prevented from rotating. Similarly it is assumed that the concrete structure or the steel member to which the joist hanger is bolted does not rotate. If the header beam only has installed a joist hanger on one side the eccentricity moment $M_v = F_d \cdot (B_H / 2 + e_{J,0})$ shall be considered. The same applies when the header has joist hanger connections on both sides, but with vertical forces which differ more than 20%.

It is a condition for a force F_{lat} perpendicular to the vertical symmetry line that the joist hanger is connected to a wood-based header with nails in all holes (full nailing) or in all holes marked for partial nailing.

The joist hangers are intended for use for connections subject to static or quasi static loading.

The zinc-coated hangers are for use in timber structures subject to the dry, internal conditions defined by the service classes 1 and 2 of EN 1995-1-1:2004, (Eurocode 5).

The joist hangers can also be used in outdoor timber structures, service class 3, when a corrosion protection in accordance with Eurocode 5 is applied, or when stainless steel with similar or better characteristic yield and ultimate strength is employed

The scope of the brackets regarding resistance to corrosion shall be defined according to national provisions that apply at the installation site considering environmental conditions.

The provisions made in this European Technical Assessment are based on an assumed intended working life of the hold downs of 50 years.

The indications given on the working life cannot be interpreted as a guarantee given by the producer or Assessment Body, but are to be regarded only as a means for choosing the right products in relation to the expected economically reasonable working life of the works.

3 Performance of the product and references to the methods used for its assessment

Characteristic	Assessment of characteristic
3.1 Mechanical resistance and stability*) (BWR1)	
Characteristic load-carrying capacity	See Annex B
Stiffness	No performance assessed
Ductility in cyclic testing	No performance assessed
3.2 Safety in case of fire (BWR2)	
Reaction to fire	The joist hangers are made from steel classified as Euroclass A1 in accordance with EN 1350-1 and EC decision 96/603/EC, amended by EC Decision 2000/605/EC
3.3 General aspects related to the performance of the product	The joist hangers have been assessed as having satisfactory durability and serviceability when used in timber structures using the timber species described in Eurocode 5 and subject to the conditions defined by service class 1, 2 and 3
Identification	See Annex A

*) See additional information in section 3.4 – 3.7.

3.4 Methods of verification

Safety principles and partial factors

The characteristic load-carrying capacities are based on the characteristic values of the nail connections and the joist hangers. To obtain design values the capacities have to be divided by different partial factors for the material properties, the nail connection in addition multiplied with the coefficient k_{mod} .

According to EN 1990 (Eurocode – Basis of design) paragraph 6.3.5 the design value of load-carrying capacity may be determined by reducing the characteristic values of the load-carrying capacity with different partial factors.

Thus, the characteristic values of the load-carrying capacity are determined also for timber failure $F_{Rk,H}$ (obtaining the embedment strength of nails subjected to shear or the withdrawal capacity of the most loaded nail, respectively) as well as for steel plate failure $F_{Rk,S}$. The design value of the load-carrying capacity is the smaller value of both load-carrying capacities.

$$F_{Rd} = \min \left\{ \frac{k_{mod} \cdot F_{Rk,H}}{\gamma_{M,H}}; \frac{F_{Rk,S}}{\gamma_{M,S}} \right\}$$

Therefore, for timber failure the load duration class and the service class are included. The different partial factors γ_M for steel or timber, respectively, are also correctly taken into account.

3.5 Mechanical resistance and stability

See annex B for characteristic load-carrying capacities of the joist hangers.

The characteristic capacities of the joist hangers are determined by calculation assisted by testing as described in EAD 130186-00-0603. They should be used for designs in accordance with Eurocode 5 or a similar national Timber Code.

The design models allow the use of fasteners described in the table on page 11 in Annex A:

Threaded nails (ringed shank nails) in accordance to EN 14592

In the formulas in Annex B the capacities for threaded nails calculated from the formulas of Eurocode 5 are used assuming a thick steel plate when calculating the lateral nail load-carrying-capacity.

Further, the joist hangers may be fastened to a concrete structure or steel member by bolts with a diameter of 10 mm in holes with a diameter up to 2 mm larger than the bolt.

The load bearing capacities of the brackets has been determined based on the use of connector nails 4,0 x 40

mm in accordance with the German national approval for the nails.

The characteristic withdrawal capacity of the nails has to be determined by calculation in accordance with EN 1995-1-1: 2004, paragraph 8.3.2 (head pull-through is not relevant):

$$F_{ax,Rk} = f_{ax,k} \times d \times t_{pen}$$

Where:

$f_{ax,k}$ Characteristic value of the withdrawal parameter in N/mm²
 d Nail diameter in mm
 t_{pen} Penetration depth of the profiles shank in mm

Based on tests by Versuchsanstalt für Stahl, Holz und Steine, University of Karlsruhe, the characteristic value of the withdrawal resistance for the threaded nails used can be calculated as:

$$f_{ax,k} = 50 \times 10^{-6} \times \sigma_k^2$$

Where:

σ_k Characteristic density of the timber in kg/m³

The shape of the nail directly under the head shall be in the form of a truncated cone with a diameter under the nail head which exceeds the hole diameter.

4,0 mm threaded nails with a truncated cone below the head are used as fasteners, which are particularly suitable for nailed steel-to-timber connections. The specific shape below the head causes a clamping of nails in the steel plate.

No performance has been determined in relation to ductility of a joint under cyclic testing. The contribution to the performance of structures in seismic zones, therefore, has not been assessed.

No performance has been determined in relation to the joint's stiffness properties - to be used for the analysis of the serviceability limit state.

3.6 Aspects related to the performance of the product

3.6.1 Corrosion protection in service class 1 and 2.

The joist hangers have a zinc coating weight of min Z275. The steel employed is S250 GD with min Z275 according to EN 10346:2009.

3.6.2 Corrosion protection in service class 3.

In accordance with Eurocode 5 connectors with a thickness up to 3 mm shall be made from stainless steel.

3.7 General aspects related to the fitness for use of the product

The joist hangers are manufactured in accordance with the provisions of this European Technical Assessment using the manufacturing processes as identified in the inspection of the plant by the notified inspection body and laid down in the technical documentation

The nailing pattern used shall be either the maximum or the minimum pattern as defined in Annex A.

The following provisions concerning product performance apply:

Joist hanger connections

A joist hanger connection is deemed fit for its intended use provided:

Header – support conditions

- The header beam shall be restrained against rotation and be free from wane under the joist hanger.

If the header carries joists only on one side the eccentricity moment from the joists $M_{ec} = R_{joist} (b_{header}/2 + e_{j,0})$ shall be considered at the strength verification of the header.

R_{joist}	Reaction force from the joists
b_{header}	Width of header
$e_{j,0}$	Distance from the centroid of the nails in the joist to the surface of the header

- For a header with joists from both sides but with different reaction forces a similar consideration applies.

Wood to wood connections

- Joist hangers are fastened to wood-based members by nails.
- There shall be nails in all holes or a partial nailing pattern as prescribed in Annex A-D may be used.
- The characteristic capacity of the joist hanger connection is calculated according to the manufacturer's technical documentation, dated 2008-11-08.
- The joist hanger connection is designed in accordance with Eurocode 5 or an appropriate national code.
- The gap between the end of the joist and the surface, where contact stresses can occur during loading shall be limited. This means that for joist hangers with outward flaps the gap between the surface of the end of the joist and that of the header shall be maximum 3 mm.

- Joist hangers with inward flaps the gap between the surface of the nail heads in the inward flaps and the end of the joist shall be maximum 8 mm.
- For joist hangers A, and B the width of the joist shall be at least $l + 4d$, where l is the length of the fasteners and d is the fastener diameter in the joist, for full nailing and partial nailing without staggering the fasteners in the joist. For nailing with staggered fasteners in the joist the width shall be at least the penetration length of the fasteners.
- The cross section of the joist at the joist hanger connection shall have sharp edges at the lower side against the bottom plate, i.e. it shall be without wane.
- The cross section of the header shall have a plane surface against the whole joist hanger.
- The width B_j of the joist shall correspond to that of the joist hanger. B_j shall not be smaller than $B - 3$ mm, where B is the inner width of the joist hanger.
- The depth of the joist shall be so large that the top of the joist is at least 20 mm above the upper fastener in the joist.
- Nails to be used shall have a diameter, which fits the holes of the joist hangers.

Wood to concrete or steel

The above mentioned rules for wood to wood connections are applicable also for the connection between the joist and the joist hanger.

- The joist hanger shall be in close contact with the concrete or steel over the whole face. There shall be no intermediate layers in between.
- The gap between the end of the joist and the surface, where contact stresses can occur during loading shall be limited. This means that the gap between the surface of the end of the joist and that of the concrete or steel shall be maximum 3 mm.
- The bolt shall have a diameter not less than the hole diameter minus 2 mm.
- The bolts shall be placed symmetrically about the vertical symmetry line. There shall always be bolts in the 2 upper holes.
- The upper bolts shall have washers according to EN ISO 7094.

4 Attestation and verification of constancy of performance (AVCP)

4.1 AVCP system

According to the decision 97/638/EC of the European Commission¹, as amended, the system(s) of assessment and verification of constancy of performance (see Annex V to Regulation (EU) No 305/2011) is 2+.

5 Technical details necessary for the implementation of the AVCP system, as foreseen in the applicable EAD

Technical details necessary for the implementation of the AVCP system are laid down in the control plan deposited at ETA-Danmark prior to CE marking.

Issued in Copenhagen on 2021-04-06 by



Thomas Bruun
Managing Director, ETA-Danmark

Annex A
Product details and definitions

Joist hanger type A

Face mount hanger with external flanges. 2.0 mm thick hot-dipped coated steel SD250GD + Z (min Z275) according to EN 10346:2009 with a minimum R_e of 250 MPa, a minimum tensile strength R_m of 330 MPa and a minimum ultimate strain A_{80} of 22 % with tolerances according to EN 10143.

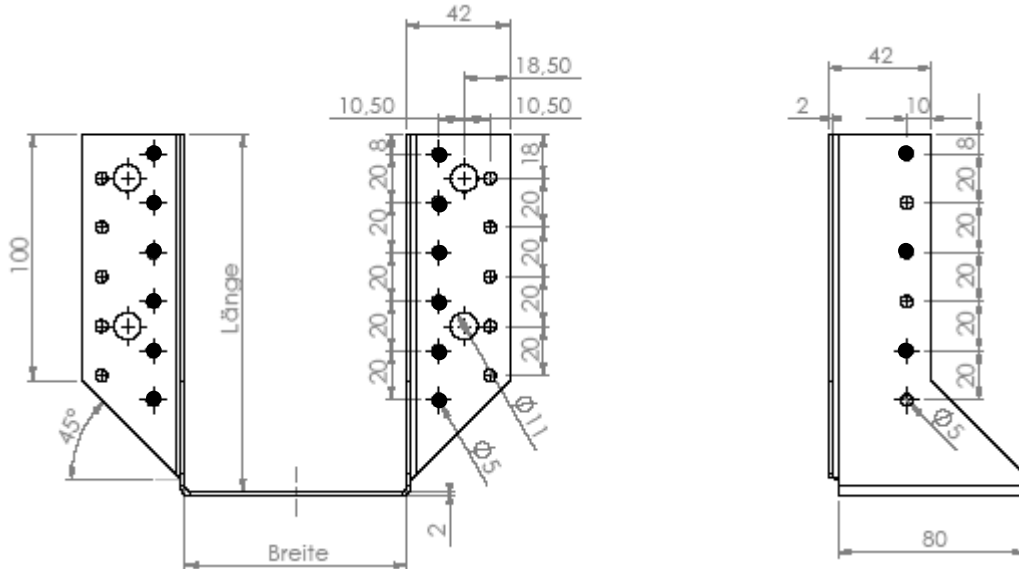

- Partial nailing; Drawing: Blank 380, 2,0 mm steel

Blank	Total n° of nail holes		Width interval		Height interval		Bolt holes		A
	n _H	n _J	min	max	min	max	n°	d	
230	10	6	51	64	83	90	2	11	= B + 84
260	14	8	25	70	95	118	4	11	= B + 84
300	18	10	60	64	118	120	4	11	= B + 84
320	18	10	40	80	120	140	4	11	= B + 84
360	20	10	80	80	140	140	4	11	= B + 84
380	22	12	60	100	140	160	4	11	= B + 84
420	24	14	100	100	160	160	4	11	= B + 84
440	26	14	40	120	160	200	4	11	= B + 84
480	28	16	120	120	180	180	4	11	= B + 84
500	30	16	60	140	180	220	6	11	= B + 84

Joist hanger's height = (blank – width)/2

Joist hanger type A

Face mount hanger with external flanges. 2.5 mm thick hot-dipped coated steel SD250GD + Z (min Z275) according to EN 10346:2009 with a minimum R_e of 250 MPa, a minimum tensile strength R_m of 330 MPa and a minimum ultimate strain A_{80} of 22 % with tolerances according to EN 10143.

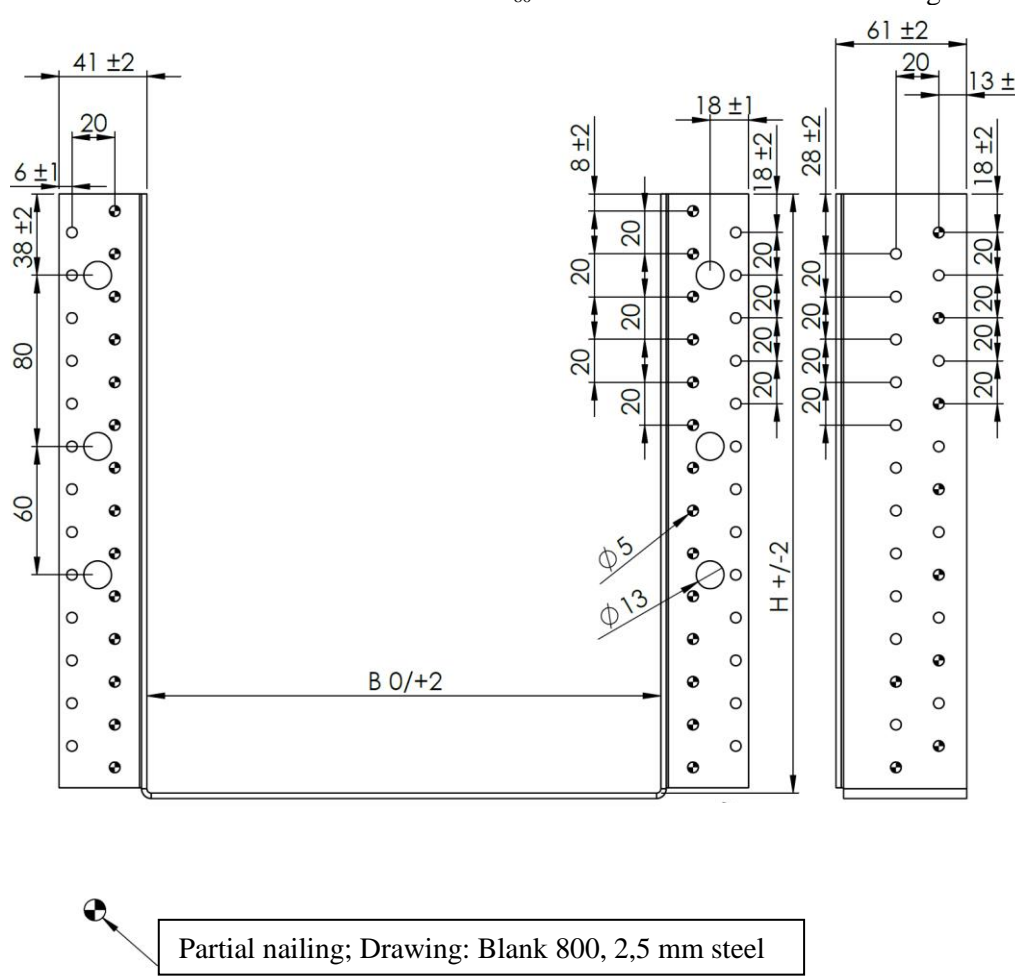

Blank	Total n° of nail holes		Width interval B		Height interval H		Bolt holes		A
	n _H	n _J	min	max	min	max	n°	d	
480	30	14	160	160	160	160	4	13	= B + 82
540	34	16	140	180	180	200	4	13	= B + 82
560	38	18	160	160	200	200	4	13	= B + 82
580	38	18	100	180	200	240	6	13	= B + 82
600	38	18	120	200	200	240	6	13	= B + 82
620	42	20	140	180	220	240	6	13	= B + 82
640	46	22	160	160	240	240	6	13	= B + 82
660	46	22	100	180	240	280	6	13	= B + 82
680	46	22	120	200	240	280	6	13	= B + 82
700	52	24	100	140	280	300	6	13	= B + 82
720	54	26	120	160	280	300	6	13	= B + 82
740	50	24	100	220	260	320	6	13	= B + 82
760	54	26	120	200	280	320	6	13	= B + 82
780	60	28	140	140	320	320	6	13	= B + 82
800	54	26	160	240	280	320	6	13	= B + 82
820	60	28	180	180	320	320	6	13	= B + 82

Joist hanger's height = (blank – width)/2

Joist hanger type B

Face mount hanger with interior flanges. 2.0 mm thick hot-dipped coated steel SD250GD + Z (min Z275) according to EN 10346:2009 with a minimum R_e of 250 MPa, a minimum tensile strength R_m of 330 MPa and a minimum ultimate strain A_{80} of 22 % with tolerances according to EN 10143.

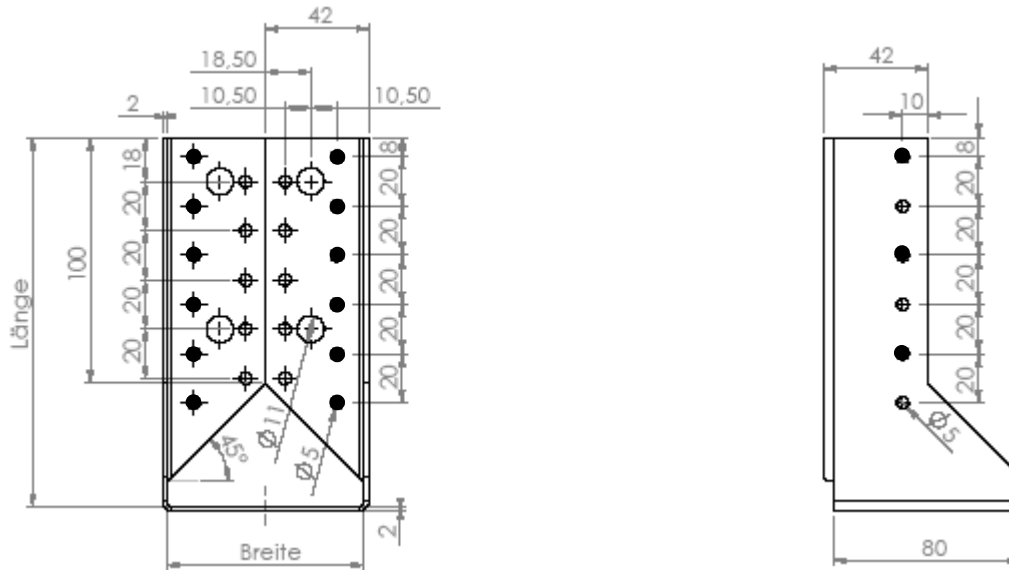

- Partial nailing; Drawing: Blank 380, 2,0 mm steel

Blank	Total n° of nail holes		Width interval		Height interval	
	n_H	n_J	min	max	min	max
260	8	8	60	60	100	100
320	18	10	80	80	120	120
380	22	12	70	100	140	155
420	24	14	140	140	140	140
440	26	14	80	120	160	180
500	30	16	100	140	180	200

Joist hanger's height = (blank – width)/2

Joist hanger type I

Face mount hanger with internal flanges. 2.5 mm thick hot-dipped coated steel SD250GD + Z (min Z275) according to EN 10346:2009 with a minimum R_e of 250 MPa, a minimum tensile strength R_m of 330 MPa and a minimum ultimate strain A_{80} of 22 % with tolerances according to EN 10143.

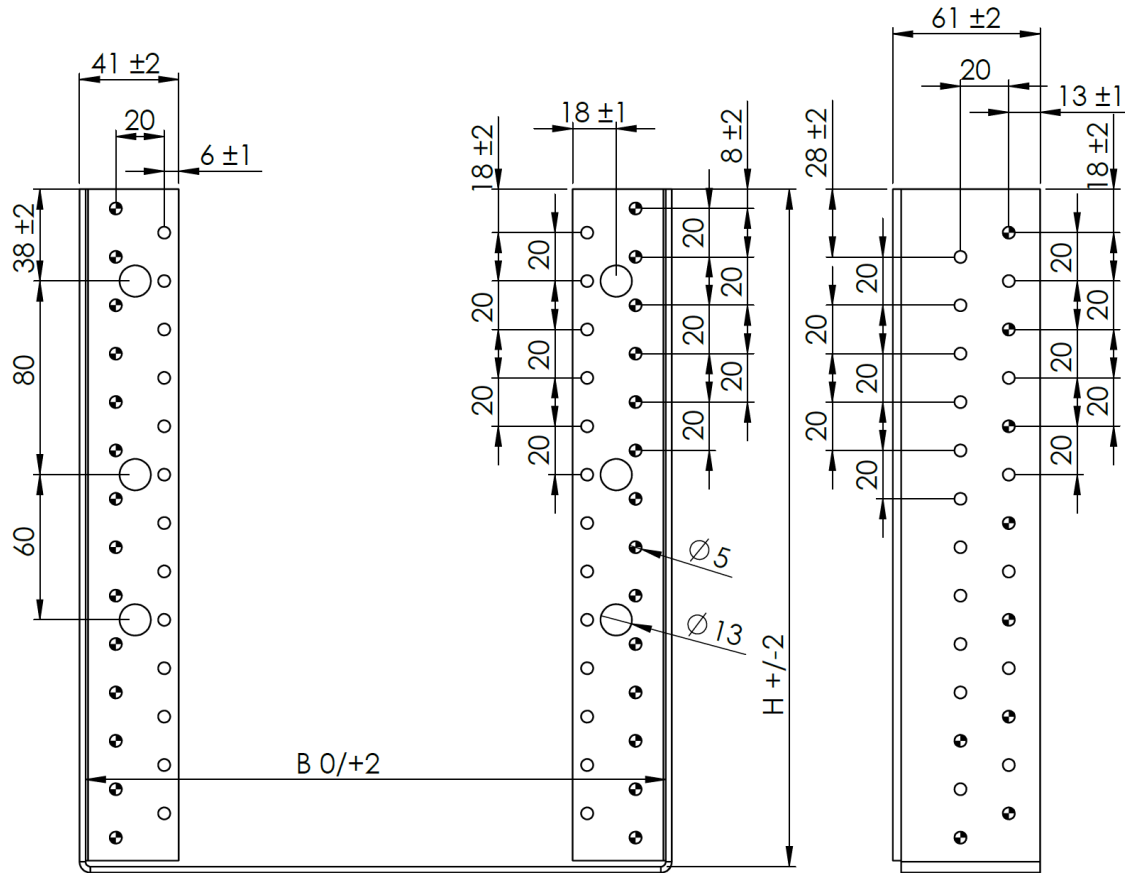

Partial nailing; Drawing: Blank 800, 2,5 mm steel

Blank	Total n° of nail holes		Width interval B		Height interval H		Bolt holes		
	n_H	n_J	min	max	min	max	n°	d	A
480	30	14	160	160	160	160	4	13	= B - 77
540	34	16	140	180	180	200	4	13	= B - 77
560	38	18	160	160	200	200	4	13	= B - 77
580	38	18	100	180	200	240	6	13	= B - 77
600	38	18	120	200	200	240	6	13	= B - 77
620	42	20	140	180	220	240	6	13	= B - 77
640	46	22	160	160	240	240	6	13	= B - 77
660	46	22	100	180	240	280	6	13	= B - 77
680	46	22	120	200	240	280	6	13	= B - 77
700	52	24	100	140	280	300	6	13	= B - 77
720	54	26	120	160	280	300	6	13	= B - 77
740	50	24	100	220	260	320	6	13	= B - 77
760	54	26	120	200	280	320	6	13	= B - 77
780	60	28	140	140	320	320	6	13	= B - 77
800	54	26	160	240	280	320	6	13	= B - 77
820	60	28	180	180	320	320	6	13	= B - 77

Joist hanger's height = (blank – width)/2

Fastener types and sizes

NAIL diameter	Length Min – max	Nail type
4.0	25 - 100	Ringed shank nails according to EN 14592
<p>In the formulas in Annex B the capacities for threaded nails calculated from the formulas of Eurocode 5 are used assuming a thick steel plate when calculating the lateral nail load-carrying-capacity. The load bearing capacities of the joist hangers has been determined based on the use of connector nails 4,0 x L mm in accordance with the German national approval for the nails. The characteristic withdrawal capacity of the nails has to be determined by calculation in accordance with EN 1995-1-1: 2004, paragraph 8.3.2 (head pull-through is not relevant):</p> $F_{ax,Rk} = f_{1,k} \times d \times t_{pen}$ <p>Where:</p> <p>$f_{1,k}$ Characteristic value of the withdrawal parameter in N/mm² d Nail diameter in mm t_{pen} Penetration depth of the profiled shank in mm</p> <p>Based on tests by Versuchsanstalt für Stahl, Holz und Steine, University of Karlsruhe, the characteristic value of the withdrawal resistance for the threaded nails used can be calculated as:</p> $f_{1,k} = 50 \times 10^{-6} \times \rho_k^2$ <p>Where:</p> <p>ρ_k Characteristic density of the timber in kg/m³</p> <p>The shape of the nail directly under the head shall be in the form of a truncated cone with a diameter under the nail head which exceeds the hole diameter.</p>		

BOLTS diameter	Correspondence Hole diameter	Bolts type
10.0 – 12.0	Max. 2 mm. larger than the bolt diameter	See specification of the manufacturer

Annex B

Characteristic values of load-carrying-capacities

Characteristic capacities of the joist hanger connections with nails only

The downward and the upward directed forces are assumed to act in the middle of the joist. The lateral force is assumed to act at an distance $e_{J,90}$ above the center of gravity of the nails in the joist.

Two nails patterns are specified. A full nailing pattern, where there are nails in all the holes and a partial nailing pattern, where the number of nails in the joist and the header are at least half the numbers specified for full nailing. The nails in the joist may be staggered. The nails in the header shall be put in the holes closest to the bend line.

For Gutzeit joist hangers the width of the joist shall be at least $l+4d$, where l is the length of the nails and d is the diameter of the nails in the joist, for full nailing and partial nailing without staggering the nails in the joist. For partial nailing with staggered nails in the joist the width shall be at least the penetration length of the nails.

B.1 Joist hangers types A, B and I fastened with nails

Force downward toward the bottom plate:

$$F_{Z,Rd} = \min \left\{ \frac{(n_J + 2) \cdot F_{v,J,Rd}}{1}, \sqrt{\left(\frac{1}{n_H \cdot F_{v,H,Rd}} \right)^2 + \left(\frac{1}{k_{H,1} \cdot F_{ax,H,Rd}} \right)^2} \right\} \quad (\text{B.1.1.1})$$

Force upward away from the bottom plate:

$$F_{Z,Rd} = \min \left\{ \frac{n_J \cdot F_{v,J,Rd}}{1}, \sqrt{\left(\frac{1}{n_H \cdot F_{v,H,Rd}} \right)^2 + \left(\frac{1}{k_{H,2} \cdot F_{ax,H,Rd}} \right)^2} \right\} \quad (\text{B.1.1.2})$$

Lateral force:

$$F_{Y,Rd} = \min \left\{ \frac{n_J \cdot F_{v,J,Rd}}{\sqrt{\left(\frac{2 \cdot \sqrt{e_{J,0}^2 + e_{J,90}^2}}{b_J} \right)^2 + \left(\frac{F_{v,J,Rd}}{F_{ax,J,Rd}} \right)^2}}, \frac{F_{v,H,Rd}}{\sqrt{\left(\frac{1}{n_H} + \frac{e_H}{e_1} \right)^2 + \left(\frac{e_H}{e_2} \right)^2}} \right\} \quad (\text{B.1.1.3})$$

n_J total number of nails in both sides of the joist

n_H total number of nails in the side of the header

$F_{v,Rd}$ Characteristic lateral load-carrying capacity of the fasteners in the joist or in the header indicated by the indices J or H

$F_{ax,Rd}$ Characteristic axial load-carrying capacity of the fasteners in the joist or in the header indicated by the indices J or H

b_J width of the joist hanger, see figure B1.

$e_{J,90}$ distance of the lateral force above the centre of gravity of the nails in the joist, see figure B1.

$e_{J,0}$ distance from the nails in the joist to the surface of the header, see figure B1.

e_H distance of the lateral force above the centre of gravity of the nails in the header.

e_1 joist hanger dimension, see Annex C

e_2 joist hanger dimension, see Annex C

$k_{H,1}$ form factor, see Annex C

$k_{H,2}$ form factor, see Annex C

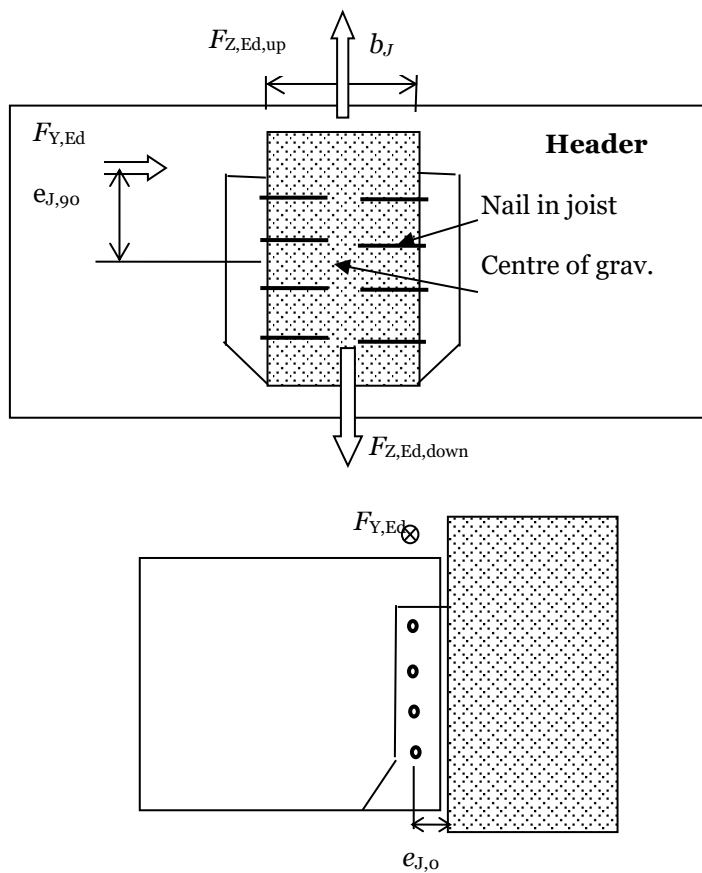

Figure B1: Definition of $e_{J,90}$ and $e_{J,0}$

B.1.2 Combined forces

In case of combined forces the following inequality shall be fulfilled:

$$\left(\frac{F_{Y,Ed}}{F_{Y,Rd}} \right)^2 + \left(\frac{F_{Z,Ed}}{F_{Z,Rd}} \right)^2 \leq 1 \quad (\text{B.1.2.1})$$

B.2 Characteristic capacities of the joist hanger type A or I, connections with bolts

For joist hangers type A connected to a wall of concrete, lightweight concrete or to a steel member the assumptions for the calculation of the load-carrying capacity of the connection are:

- The transfer of force from the joist to the joist hanger is as for a wood-wood connection, see clause B.1;
- The bolts shall always be positioned symmetrically about the vertical axis of the joist hanger;
- Washers according to EN ISO 7094 shall be installed at least under the upper 2 bolt heads or nuts.

Description of the static model

For a downward directed force toward the bottom plate the static behavior is basically the same as for a wood-wood connection with nails.

The nails in the joist are subjected to a lateral force, which is equally distributed over all nails in the joist.

Since the concrete and steel have a larger compressive strength than timber subjected perpendicular to the grain the rotation point may be assumed positioned at the top of the bottom plate.

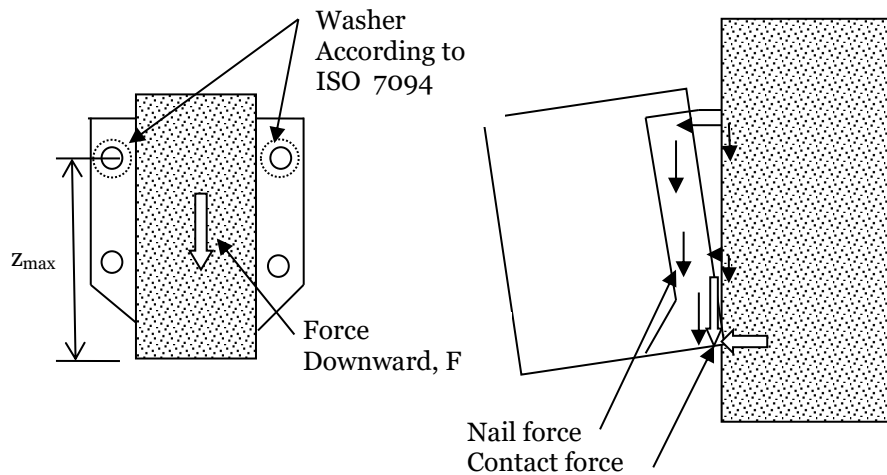

Figure B2 Left: Cross section in joist. Right: The joist will deflect and rotate, at the bottom a contact force will occur at the bottom plate, and the withdrawal forces in the bolts in the wall will vary linearly as assumed for nailed connections in the header.

The forces in the bolts will be partly lateral forces, partly withdrawal forces. The lateral forces are distributed evenly over all bolts. The withdrawal forces are on the safe side assumed to be taken by the 2 upper bolts with washers. The maximum withdrawal force in a bolt can be calculated from

$$F_{ax,bolt} = \frac{F \cdot e_{J,0}}{2 \cdot z_{max}} \quad (B.2.1)$$

Where

F downward directed force toward the bottom plate;

$e_{J,0}$ eccentricity = distance from the nail column in the joist to the surface of the header;

z_{max} max distance from upper bolt to the bottom plate (rotation point).

The upper 2 bolts are critical. They are subjected to a lateral force and a withdrawal force. The lateral force is determined assuming an even distribution of the downward force F.

$$F_{lat,bolt} = F / n_{bolt} \quad (B.2.2)$$

Characteristic capacities of a bolted joist hanger connection

The Characteristic capacity of the connection between the joist and the joist hanger may be calculated from the same assumptions and formulas as for joist hangers nailed to a wooden header beam.

$$F_{Z,Rk} = (n_J + 2) \cdot F_{v,J,Rk} \quad \text{for threaded nails} \quad (\text{B.2.3})$$

The upper 2 bolts are critical. They are subjected to a lateral force calculated from formula (B.2.2).

The withdrawal force in an upper bolt is calculated from (B.2.1).

Where

F downward directed force toward the bottom plate

n_{bolt} total number of bolts in the joist hanger

$e_{J,0}$ eccentricity = distance from the nail column in the joist to the surface of the header

z_{max} max distance from the upper bolt to the bottom plate (rotation point)

It shall be verified by the design of the bolted connection that the upper bolts have sufficient load-carrying capacity to carry the combined lateral and axial forces.

From the characteristic load-carrying-capacity of the bearing resistance between the bolt and the plate of the joist hanger the following maximum characteristic capacity of the joist hanger connection can be determined.

$$F_{\text{bear},Rk} = n_{\text{bolt}} \cdot f_{u,k} \cdot d \cdot t \quad (\text{B.2.4})$$

where

n_{bolt} total number of bolts in the 2 flaps

$f_{u,k}$ characteristic ultimate tensile strength of the steel

d diameter of the bolt

t thickness of the steel plate of the joist hanger

The characteristic load-carrying capacity of the joist hanger connections is the minimum of:

- The capacity determined from (B.2.3) from the fasteners in the joist;
- The capacity determined from (B.2.4) from the embedding strength of the steel plate against the bolt;
- The capacity controlled by the bolt forces given by (B.2.1) and (B.2.2).

Annex C
Form factors $k_{H,1}$ and $k_{H,2}$ and dimensions e_1 , e_2 and $e_{J,0}$

Table C1: Gutzeit Joist hanger type A with external flanges:
Form factors $k_{H,1}$ and $k_{H,2}$ and dimensions e_1 , e_2 and $e_{J,0}$

B [mm]	H [mm]	n_H	n_J	$k_{H,1}$	$k_{H,2}$	e_1 [mm]	e_2 [mm]	$e_{J,0}$ [mm]	n_H	n_J	$k_{H,1}$	$k_{H,2}$	e_1 [mm]	e_2 [mm]	$e_{J,0}$ [mm]
		Full nailing							Partial nailing						
51	90	10	6	11,1	2,82	1253	421	32	6	4	6,85	1,88	525	273	32
60	85	10	6	9,90	3,02	1474	461	32	6	4	6,14	2,02	635	295	32
64	83	10	6	9,38	3,13	1579	478	32	6	4	5,83	2,08	688	306	32
25	118	14	8	23,0	5,72	793	511	32	8	4	13,3	3,54	307	361	32
32	114	14	8	21,7	5,92	911	547	32	8	4	12,6	3,65	358	370	32
38	111	14	8	20,6	6,12	1022	578	32	8	4	12,0	3,76	406	381	32
40	110	14	8	20,2	6,18	1060	589	32	8	4	11,8	3,80	424	385	32
50	105	14	8	18,3	6,54	1268	645	32	8	4	10,8	4,02	518	409	32
60	100	14	8	16,6	6,94	1499	703	32	8	4	9,77	4,27	626	437	32
63	99	14	8	16,0	7,07	1573	720	32	8	4	9,47	4,35	661	446	32
70	95	14	8	14,8	7,39	1753	762	32	8	4	8,80	4,55	748	467	32
60	120	18	10	24,9	12,5	1581	988	32	10	6	14,2	7,35	662	616	32
64	118	18	10	24,0	12,8	1677	1017	32	10	6	13,8	7,50	706	628	32
40	140	18	10	34,1	10,5	1027	856	32	10	6	19,3	6,15	420	572	32
51	135	18	10	31,5	10,9	1225	927	32	10	6	17,8	6,44	507	593	32
60	130	18	10	29,4	11,4	1406	988	32	10	6	16,7	6,70	589	616	32
63	129	18	10	28,7	11,5	1469	1010	32	10	6	16,3	6,79	618	625	32
64	128	18	10	28,5	11,6	1491	1017	32	10	6	16,2	6,82	628	628	32
70	125	18	10	27,1	11,9	1625	1060	32	10	6	15,4	7,01	690	647	32
75	123	18	10	26,0	12,2	1742	1097	32	10	6	14,8	7,18	745	663	32
80	120	18	10	24,9	12,5	1864	1134	32	10	6	14,2	7,35	802	681	32
80	140	20	10	34,6	14,6	2208	1343	32	10	6	19,3	6,15	802	681	32
60	160	22	12	45,8	16,9	1703	1330	32	12	6	25,4	9,68	724	842	32
63	159	22	12	45,0	17,1	1773	1354	32	12	6	25,0	9,79	755	849	32
70	155	22	12	43,0	17,6	1945	1410	32	12	6	23,9	10,0	833	868	32
71	155	22	12	42,7	17,6	1971	1418	32	12	6	23,8	10,1	845	871	32
75	153	22	12	41,6	17,9	2075	1451	32	12	6	23,2	10,2	892	883	32
76	152	22	12	41,3	18,0	2101	1459	32	12	6	23,0	10,3	904	887	32
80	150	22	12	40,2	18,2	2209	1493	32	12	6	22,4	10,4	954	900	32
90	145	22	12	37,5	18,9	2496	1579	32	12	6	21,0	10,8	1087	937	32
100	140	22	12	34,8	19,7	2804	1669	32	12	6	19,5	11,3	1233	978	32
100	160	24	14	46,0	23,3	2618	1870	32	14	8	25,6	16,0	1299	1238	32
40	200	26	14	72,7	22,3	1333	1604	32	14	8	39,6	12,5	579	1141	32
60	190	26	14	65,9	23,6	1714	1741	32	14	8	36,0	13,2	743	1123	32
63	189	26	14	64,9	23,8	1779	1765	32	14	8	35,4	13,3	771	1126	32
71	185	26	14	62,2	24,4	1958	1832	32	14	8	34,0	13,7	851	1141	32
75	183	26	14	60,9	24,7	2053	1866	32	14	8	33,3	13,8	894	1151	32
80	180	26	14	59,2	25,1	2176	1911	32	14	8	32,4	14,0	950	1165	32
100	170	26	14	52,7	26,7	2718	2103	32	14	8	29,0	15,0	1199	1238	32
120	160	26	14	46,5	28,6	3339	2309	32	14	8	25,6	16,0	1492	1329	32
120	180	28	16	59,6	31,6	3751	2594	32	14	8	32,4	14,0	1492	1329	32
60	220	30	16	89,5	31,4	2042	2233	32	16	8	48,3	17,3	903	1469	32
75	213	30	16	83,7	32,6	2405	2355	32	16	8	45,2	18,0	1063	1473	32

Table C1 (contd.): Gutzeit Joist hanger type A with external flanges:
Form factors $k_{H,1}$ and $k_{H,2}$ and dimensions e_1 , e_2 and $e_{J,0}$

B [mm]	H [mm]	n_H	n_J	$k_{H,1}$	$k_{H,2}$	e_1 [mm]	e_2 [mm]	$e_{J,0}$ [mm]	n_H	n_J	$k_{H,1}$	$k_{H,2}$	e_1 [mm]	e_2 [mm]	$e_{J,0}$ [mm]
		Full nailing							Partial nailing						
80	210	30	16	81,8	33,0	2537	2400	32	16	8	44,2	18,2	1122	1482	32
100	200	30	16	74,2	34,9	3118	2599	32	16	8	40,2	19,2	1387	1541	32
120	190	30	16	66,9	36,9	3785	2819	32	16	8	36,3	20,3	1698	1628	32
140	180	30	16	59,8	39,2	4538	3054	32	16	8	32,6	21,6	2055	1733	32

Table C2: Joist hanger type B with interior flanges:
Form factors $k_{H,1}$ and $k_{H,2}$ and dimensions e_1 , e_2 and $e_{J,0}$

B [mm]	H [mm]	n_H	n_J	$k_{H,1}$	$k_{H,2}$	e_1 [mm]	e_2 [mm]	$e_{J,0}$ [mm]	n_H	n_J	$k_{H,1}$	$k_{H,2}$	e_1 [mm]	e_2 [mm]	$e_{J,0}$ [mm]
		Full nailing							Partial nailing						
60	100	8	8	9,77	4,27	197	363	32	8	4	9,77	4,27	197	363	32
80	120	18	10	24,9	12,5	465	721	32	10	6	14,2	7,35	365	566	32
70	155	22	12	37,2	15,2	655	1129	32	12	6	20,7	8,68	482	831	32
76	152	22	12	35,7	15,5	710	1109	32	12	6	19,9	8,87	526	822	32
80	150	22	12	40,2	18,2	655	1129	32	12	6	22,4	10,4	482	831	32
100	140	22	12	34,8	19,7	870	1115	32	12	6	19,5	11,3	645	827	32
140	140	24	14	34,9	27,1	1569	1596	32	14	8	19,5	18,6	1186	1206	32
80	180	26	14	59,2	25,1	753	1688	32	14	8	32,4	14,0	526	1178	32
100	170	26	14	52,7	26,7	947	1579	32	14	8	29,0	15,0	672	1120	32
120	160	26	14	46,5	28,6	1222	1621	32	14	8	25,6	16,0	862	1143	32
100	200	30	16	74,0	35,9	1424	2191	32	14	8	39,6	12,5	728	1120	32
120	190	30	16	66,7	37,9	1752	2146	32	14	8	36,0	13,2	934	1143	32
140	180	30	16	59,7	40,3	2180	2217	32	14	8	32,4	14,0	1186	1206	32

Table C3:

Joist hanger type A with exterior flanges:

Form factors $k_{H,1}$ and $k_{H,2}$ and dimensions e_1 , e_2 and $e_{J,0}$

B [mm]	H [mm]	n_H	n_J	$k_{H,1}$	$k_{H,2}$	e_1 [mm]	e_2 [mm]	$e_{J,0}$ [mm]	n_H	n_J	$k_{H,1}$	$k_{H,2}$	e_1 [mm]	e_2 [mm]	$e_{J,0}$ [mm]
		Full nailing							Partial nailing						
160	280	46	18	34,2	33,3	2293	2378	43,6	16	10	18,7	18,2	1521	1578	44,0
140	260	46	20	54,4	42,5	2045	2845	44,0	18	10	29,4	23,2	1344	1870	44,0
180	240	46	20	43,5	42,5	3033	3130	44,0	18	10	23,7	23,2	1951	2014	44,0
160	300	52	22	54,0	52,8	2730	3641	44,4	20	12	28,9	28,4	1746	2328	44,7
100	280	52	22	78,8	52,8	1640	3937	44,4	20	12	41,8	28,4	1046	2510	44,7
180	300	54	22	54,0	52,8	3263	3789	44,4	20	12	28,9	28,4	2068	2402	44,7
120	280	54	22	78,8	52,8	1919	3637	44,4	20	12	41,8	28,4	1235	2339	44,7
200	320	50	22	54,0	52,8	3879	3990	44,4	20	12	28,9	28,4	2435	2504	44,7
140	300	50	26	80,9	66,2	2549	4432	43,4	22	14	44,3	36,4	1607	2795	42,3
180	280	50	26	67,4	66,2	3523	4545	43,4	22	14	37,1	36,4	2201	2840	42,3
160	260	50	28	80,3	78,9	3285	5354	43,7	24	16	43,5	42,8	2034	3315	43,0
100	320	54	28	110	78,9	2208	6477	43,7	24	16	59,4	42,8	1347	3951	43,0
140	300	54	28	94,9	78,9	2843	5438	43,7	24	16	51,2	42,8	1761	3370	43,0
180	280	54	28	80,3	78,9	3812	5410	43,7	24	16	43,5	42,8	2350	3336	43,0
120	320	60	28	110	78,9	2484	5751	43,7	24	16	59,4	42,8	1532	3548	43,0
160	320	54	28	94,9	78,9	3285	5354	43,7	24	16	51,2	42,8	2034	3315	43,0
200	280	54	28	80,3	78,9	4422	5559	43,7	24	16	43,5	42,8	2710	3407	43,0
100	320	60	30	127	105	2809	8987	44,0	26	16	68,3	50,4	1518	4858	43,0
140	280	46	30	110	105	3459	7218	44,0	26	16	59,5	50,4	1930	4027	43,0
120	260	46	32	126	108	3157	8641	44,3	28	18	67,5	57,9	1886	5162	43,6
160	240	46	32	109	108	3953	7612	44,3	28	18	58,7	57,9	2381	4586	43,6
100	300	52	30	144	92,8	2533	8104	44,0	26	16	77,5	50,4	1518	4858	43,0
140	280	52	30	127	92,8	3164	6604	44,0	26	16	68,3	50,4	1930	4027	43,0
180	300	54	30	110	92,8	4129	6394	44,0	26	16	59,5	50,4	2515	3894	43,0
220	280	54	30	94,3	92,8	5428	6680	44,0	26	16	51,2	50,4	3273	4028	43,0
120	320	50	32	144	108	3157	8641	44,3	28	18	76,8	57,9	1886	5162	43,6
160	300	50	32	126	108	3953	7612	44,3	28	18	67,5	57,9	2381	4586	43,6
200	280	50	32	109	108	5080	7548	44,3	28	18	58,7	57,9	3049	4530	43,6
140	260	50	36	147	140	4221	10276	43,6	30	18	76,9	66,6	2308	5621	43,6
160	320	54	32	144	108	3953	7612	44,3	28	18	76,8	57,9	2381	4586	43,6
240	300	54	32	109	108	6540	7909	44,3	28	18	58,7	57,9	3889	4703	43,6
180	280	54	36	147	140	5206	9405	43,6	30	18	76,9	66,6	2887	5215	43,6

Table C4: Gutzeit joist hanger type I with internal flanges:
Form factors $k_{H,1}$ and $k_{H,2}$ and dimensions e_1 , e_2 and $e_{J,0}$

B [mm]	H [mm]	n_H	n_J	$k_{H,1}$	$k_{H,2}$	e_1 [mm]	e_2 [mm]	$e_{J,0}$ [mm]	n_H	n_J	$k_{H,1}$	$k_{H,2}$	e_1 [mm]	e_2 [mm]	$e_{J,0}$ [mm]
		Full nailing							Partial nailing						
160	280	46	18	34,2	33,3	5243	3277	43,6	16	10	18,7	18,2	2457	1849	44,0
140	260	46	20	54,4	42,5	4614	3619	44,0	18	10	29,4	23,2	2150	2072	44,0
180	240	46	20	43,5	42,5	6338	4156	44,0	18	10	23,7	23,2	2987	2320	44,0
160	300	52	22	54,0	52,8	5656	4545	44,4	20	12	28,9	28,4	2655	2570	44,7
100	280	52	22	78,8	52,8	3466	3804	44,4	20	12	41,8	28,4	1615	2308	44,7
180	300	54	22	54,0	52,8	6555	4836	44,4	20	12	28,9	28,4	3091	2701	44,7
120	280	54	22	78,8	52,8	4111	4022	44,4	20	12	41,8	28,4	1918	2364	44,7
200	320	50	22	54,0	52,8	7539	5140	44,4	20	12	28,9	28,4	3571	2844	44,7
140	300	50	26	80,9	66,2	5100	5000	43,4	22	14	44,3	36,4	2396	2886	42,3
180	280	50	26	67,4	66,2	6806	5578	43,4	22	14	37,1	36,4	3214	3120	42,3
160	260	50	28	80,3	78,9	6195	6085	43,7	24	16	43,5	42,8	2927	3462	43,0
100	320	54	28	110	78,9	4023	5397	43,7	24	16	59,4	42,8	1906	3328	43,0
140	300	54	28	94,9	78,9	5388	5810	43,7	24	16	51,2	42,8	2543	3370	43,0
180	280	54	28	80,3	78,9	7087	6390	43,7	24	16	43,5	42,8	3355	3583	43,0
120	320	60	28	110	78,9	4664	5576	43,7	24	16	59,4	42,8	2203	3319	43,0
160	320	54	28	94,9	78,9	6195	6085	43,7	24	16	51,2	42,8	2927	3462	43,0
200	280	54	28	80,3	78,9	8062	6718	43,7	24	16	43,5	42,8	3826	3724	43,0
100	320	60	30	127	105	4727	6918	44,0	26	16	68,3	50,4	2073	3949	43,0
140	280	46	30	110	105	6149	7234	44,0	26	16	59,5	50,4	2706	3912	43,0
120	260	46	32	126	108	5329	7531	44,3	28	18	67,5	57,9	2548	4537	43,6
160	240	46	32	109	108	6852	7953	44,3	28	18	58,7	57,9	3263	4561	43,6
100	300	52	30	144	92,8	4344	6358	44,0	26	16	77,5	50,4	2073	3949	43,0
140	280	52	30	127	92,8	5781	6735	44,0	26	16	68,3	50,4	2706	3912	43,0
180	300	54	30	110	92,8	7491	7308	44,0	26	16	59,5	50,4	3512	4092	43,0
220	280	54	30	94,3	92,8	9534	8001	44,0	26	16	51,2	50,4	4491	4382	43,0
120	320	50	32	144	108	5398	7545	44,3	28	18	76,8	57,9	2548	4537	43,6
160	300	50	32	126	108	6937	7980	44,3	28	18	67,5	57,9	3263	4561	43,6
200	280	50	32	109	108	8808	8609	44,3	28	18	58,7	57,9	4150	4775	43,6
140	260	50	36	147	140	6960	9461	43,6	30	18	76,9	66,6	3076	5189	43,6
160	320	54	32	144	108	6937	7980	44,3	28	18	76,8	57,9	3263	4561	43,6
240	300	54	32	109	108	11012	9356	44,3	28	18	58,7	57,9	5210	5092	43,6
180	280	54	36	147	140	8726	9932	43,6	30	18	76,9	66,6	3873	5265	43,6

Annex D Installation of joist hangers

Joist hanger in wood/wood connection

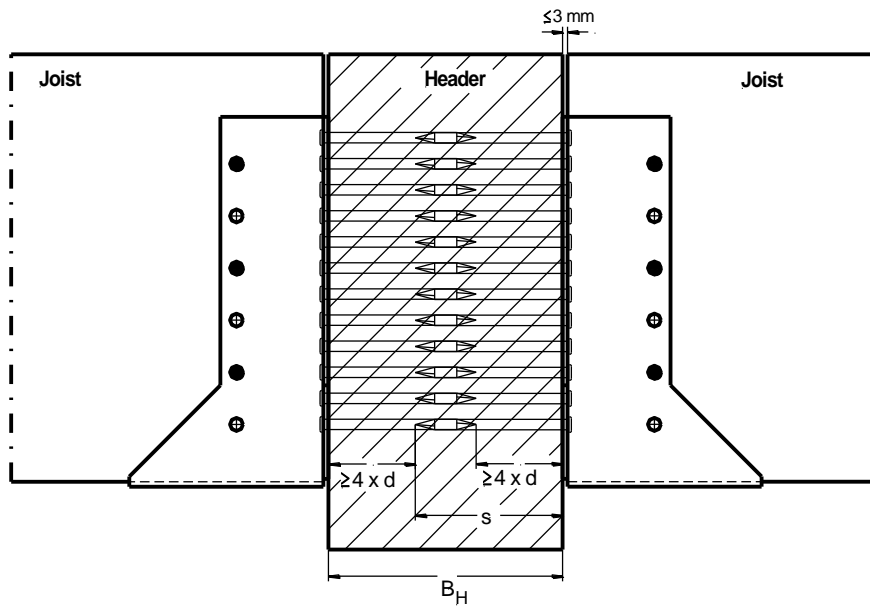
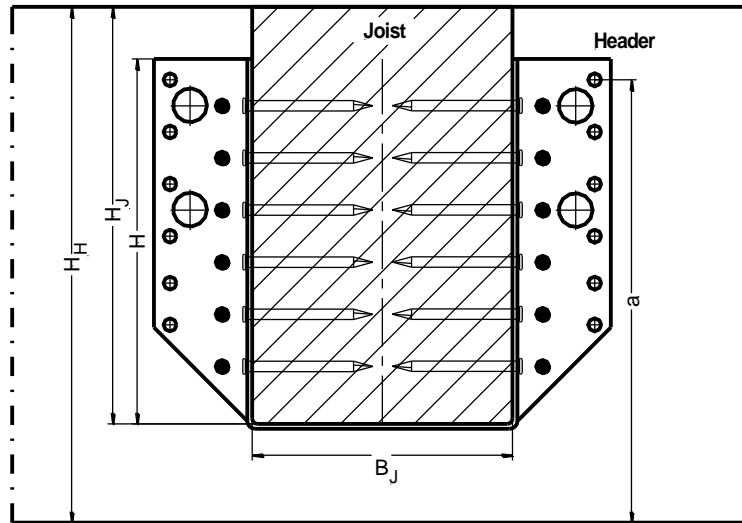

**Joist hanger connected to concrete, lightweight concrete
or a steel member by bolts**

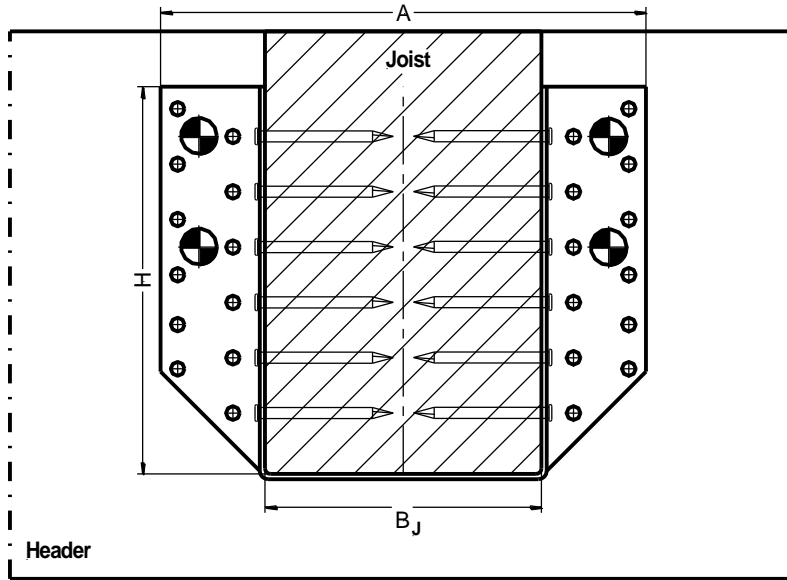

Bolts M10
Washer according to
EN ISO 7094

